

EE 205 Circuit Theory

Lab 5

Capacitance and Capacitors

The objective of this lab is to experiment the voltage-current and energy storage characteristics of a capacitor.

Consider the following circuit in Fig.1.

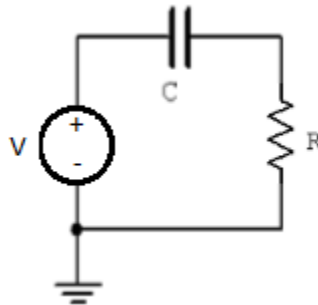

Fig.1. Test circuit for capacitor analysis

The KVL equation for this circuit is given as

$$V = V_C + IR$$

and

$$I = C \frac{dV_C}{dt}$$

Lab procedure

1. Implement the circuit given in Fig.1. where $C=15$ nF and $R=1$ k.
Take the voltage source V as a sin wave with 2V amplitude (4V peak to peak amplitude) at 1kHz frequency.
Observe the source voltage and the voltage across the resistor simultaneously at CH1 and CH2 of the oscilloscope terminals respectively.
Measure the amplitude, the frequency and the phase angle for the voltage across the resistor. Record these values into Table 1.

Table 1. Voltage measurements across the resistor

Amplitude	Frequency	Phase	Expression for V_R	Expression for current

Determine the current in the circuit from:

$$I = \frac{V_R}{R}$$

Also, record this current into Table 1.

2. Now, we will determine the current in the circuit computationally. We use the relation

$$I = C \frac{dV_C}{dt}$$

Where $V_C = V - V_R$, $V = 2 \sin(2000\pi t)$ V and V_R can be obtained from Table 1.

Also you can use the trigonometric identity

$$a \cos x + b \sin x \text{ can be written as } R \cos(x - \alpha)$$

where

$$R = \sqrt{a^2 + b^2}, \quad \tan \alpha = \frac{b}{a}$$

Write the calculated current expression: _____.

3. This time, use a triangular wave as the source at 1 kHz. Peak amplitude is 2V. What signal shape do you expect to see for the current in the circuit? Draw the oscilloscope results for V_{source} and V_R vs. time at CH1 and CH2 terminals.

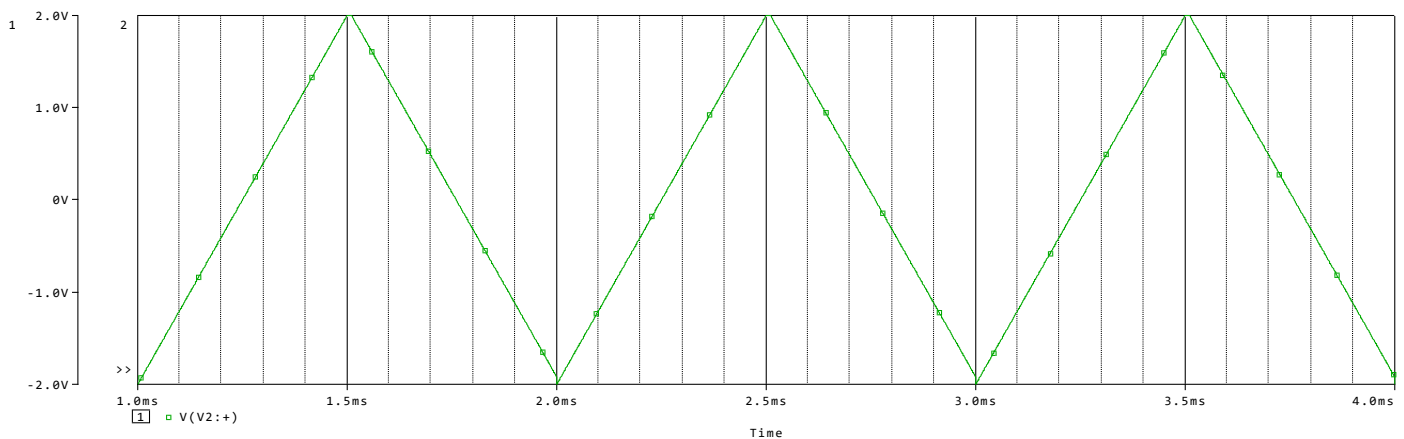

4. In this last step, we will measure the energy storage inside the capacitor. Connect the circuit in Fig.1 with V =square wave at 1kHz, 2V to -2V peak voltages. $C=0.1\mu\text{F}$ and $R=1\text{k}\Omega$. Measure the time for the resistor to discharge. You can always change the frequency for proper measurement of discharge. Record this value into Table 2.

Repeat the same procedure for C=1uF. Record the value into Table 2.

Table 2. Capacitor discharge times

Time of discharge for C=0.1uF	Time of discharge for C=1uF	Energy Measured	Energy Calculated

Now, the energy discharging of a capacitor is given as

$$V_R(t) = V_0 e^{-\frac{t}{RC}}$$

where V_0 =Initial voltage.

Since power is given by

$$P = \frac{V_R^2}{R}$$

Then, the total stored energy is

$$E = \int_0^{t_{discharge}} V_0 e^{-\frac{t}{RC}} dt$$

Can be calculated numerically for C=0.1 uF and C=1uF separately.

Compare these values with the theoretical values from

$$E = \frac{1}{2} CV^2$$

Results and Discussion:

Briefly explain the results.